

STDF Content Requirements for Scan Fault Analysis

Jan 24, 2007

Phil Burlison

Inovys Corporation



Overview of Objective

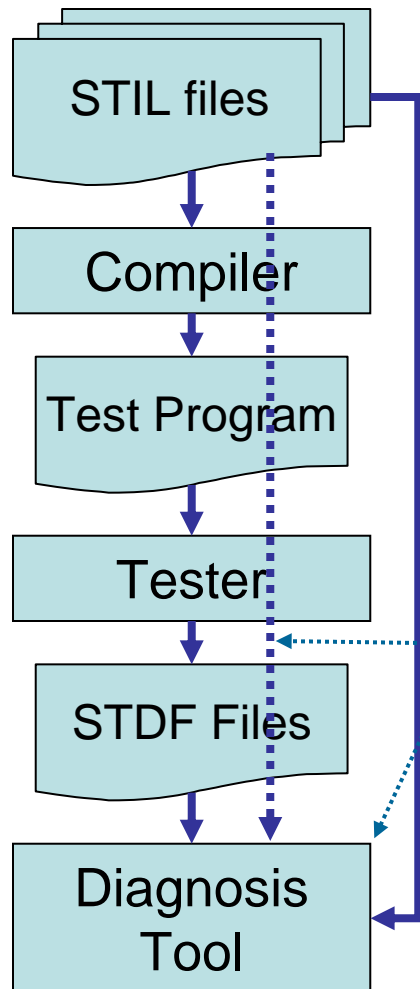

- The ultimate target of an STDF file is an offline SW fault diagnosis tool
- The original STIL files used to create the test program will often be used by the diagnosis tool to process the faults
- The STDF file must contain sufficient information to facilitate linking the failure information to the objects that were applicable in the originating STIL file(s). This is information that is not necessarily required for test

STIL Pattern Hierarchy

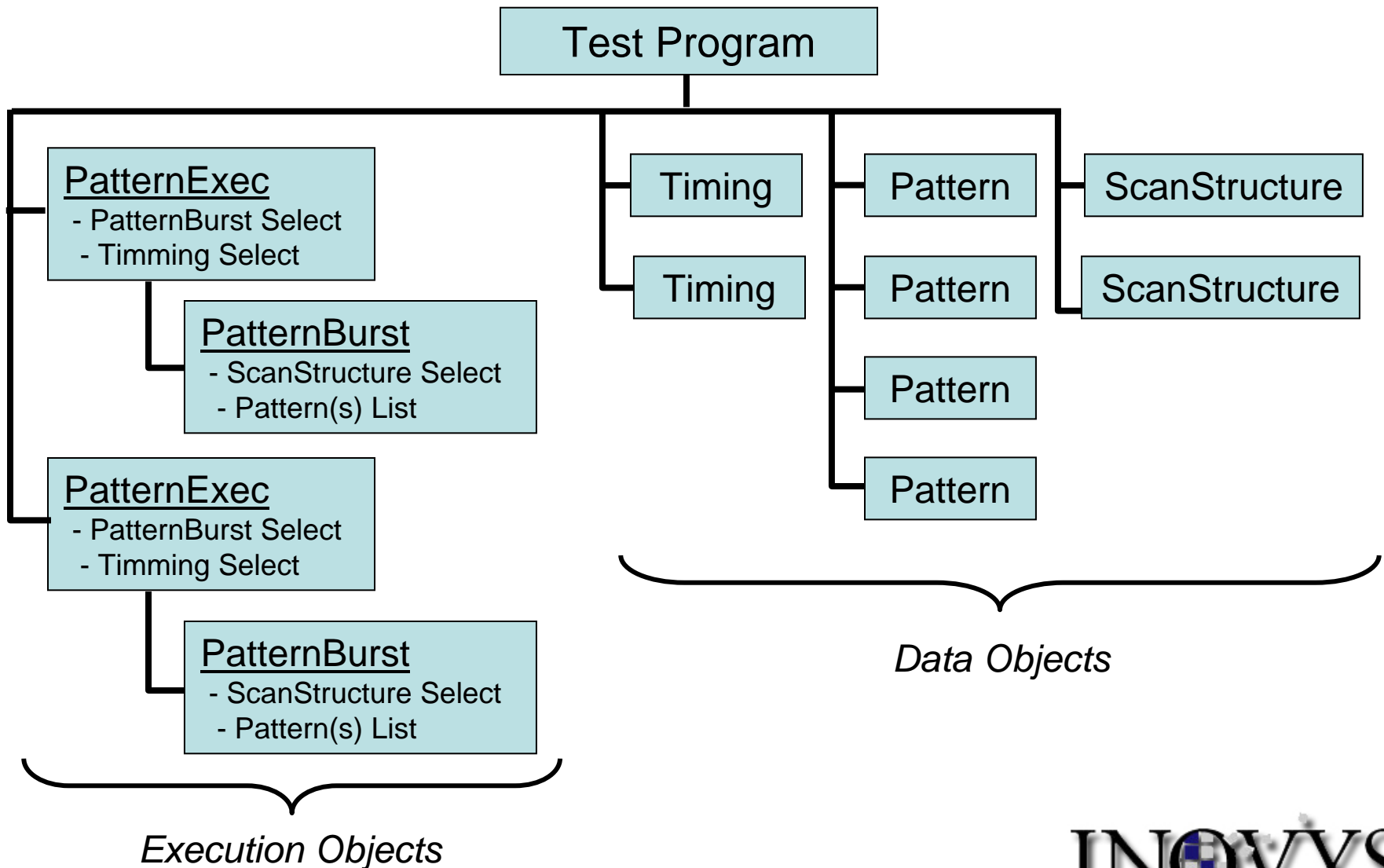

Complex Test Program Example

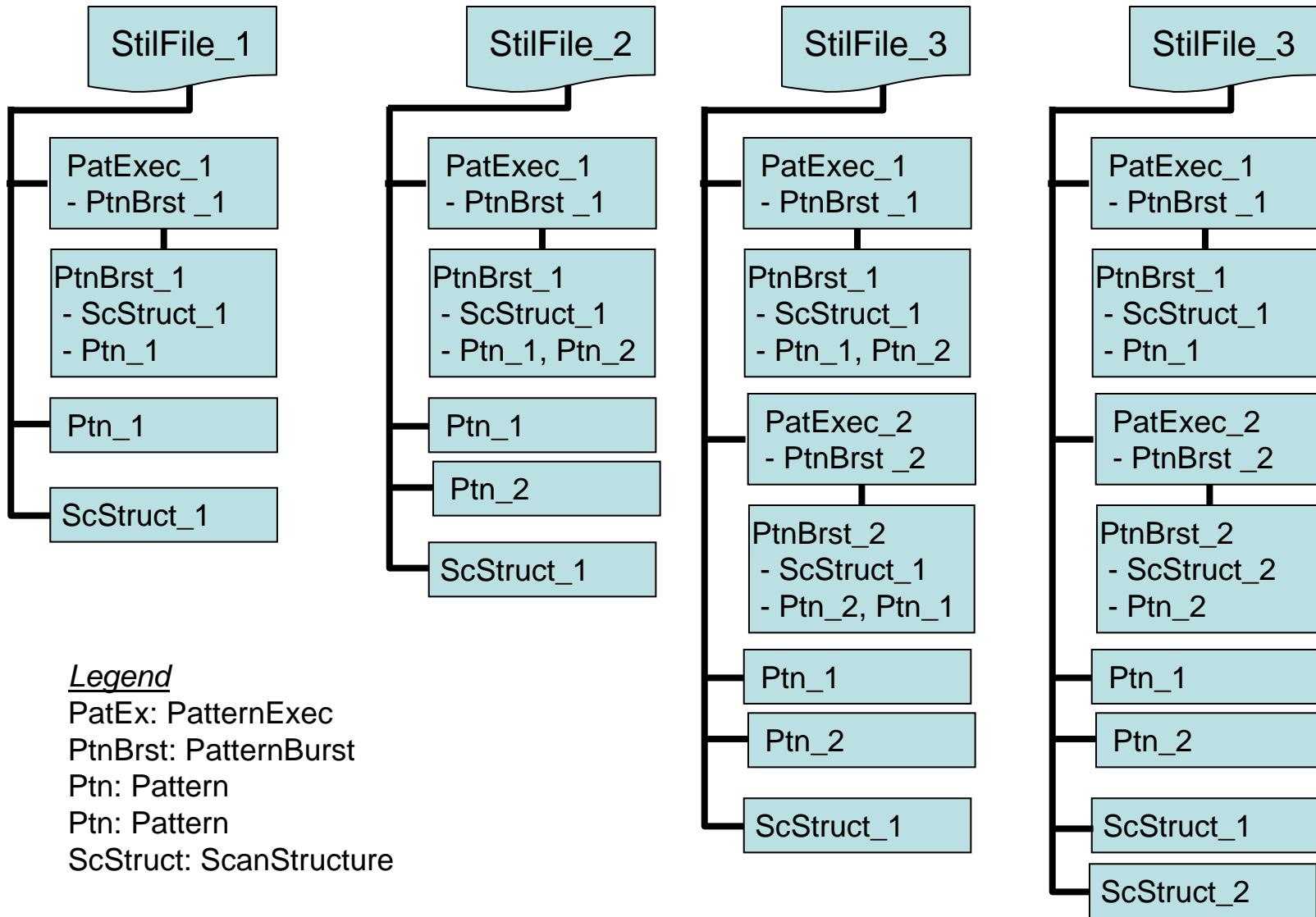

Comments on this example are on following slide

Complex Test Program Notes

- The previous slide depicted a test program that was created from 4 different STIL files
- The 1st file contained one only one pattern (this is most typical of STIL files generated by a single ATPG run).
- Object name are often common across multiple STIL files and need to be renamed with unique identifiers. One effective method to do this would be to prefix each object name with the STIL file name
- The 2nd file added two new patterns. The ScanStructure objects are expected to be the same.
- The 3rd file added two additional PatternExec objects. In this example with same patterns but with different pattern execution sequences.
- The 4th file added two new patterns with a different ScanStructure object for each pattern. This would be the case when you have a both a compressed pattern and a bypass pattern.
- Normally each PatternBurst object is an independently executed test
- The STDF datalog content must clearly link to what objects a set of failure are referenced to. Including either the PatternBurst or Pattern object name would accomplish this